

# MITSUBISHI

**KM170-5**

**KM171-5**

**KM172-5** with electric harness sq. plug on top

**KM172-7** with electric harness sq. plug on top

**F3 A21-2** with electric harness sq. plug on top

**F3 A22-2** with electric harness sq. plug on top

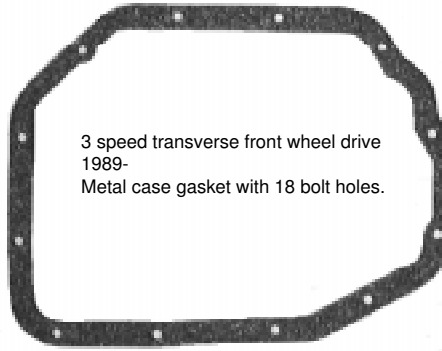

3 speed transverse front wheel drive  
1989-  
Metal case gasket with 18 bolt holes.



Iss 10/08/98

Illus	Description		Part No.
<b>KITS</b>			
	Master	84-	160 01 02
	Overhaul	79-86	160 02 02
	Gasket & rubber		160 03 02
	Bush Kit		160 09 01
<b>GASKETS</b>			
	Pan (combination - cut to suit)		160 25 01
	Case to converter housing		160 25 02
	Oil pump	(1) 79-81	160 25 04
	Oil pump	(2) 82-	160 25 05
	Filter		160 25 06
	Pump bolts	(6)	126 25 02
<b>RUBBER COMPONENTS</b>			
	Pressure check plug "O" ring	(7)	160 16 01
	Manual control shaft "O" ring	(2)	160 16 02
	Front clutch inner "O" ring		160 16 03
	Front clutch outer "O" ring		160 16 04
	Rear clutch inner "O" ring		160 16 05
	Rear clutch outer "O" ring		160 16 06
	Servo piston "O" ring 1.693"		160 16 07
	Servo piston "O" ring 2.835"		160 16 08
	Servp piston sleeve "O" ring 2.914"		160 16 09
	Lor/rev outer		160 16 10
	Low/rev inner		160 16 11
	Pump housing		160 16 12
	Transfer shaft idler		160 16 13
<b>METAL CLAD SEALS</b>			
	Converter (43/60/9)		160 15 01
	Driveshafts (35/56/9)	(2)	160 15 02
<b>SHAFT SEALING RINGS</b>			
	Pump	(2)	160 26 01
	Governor	(3)	160 26 02
	Rear clutch retainer 33mm	(1)	160 26 03
	Input shaft early 24mm	(3)	160 26 04
	Input shaft late 26mm	(3)	160 26 05
	Accumulator outer		160 26 06
	Accumulator inner		160 26 07
	Kickdown piston 1600cc	84-	160 26 08
	Kickdown piston 1500 & 2000cc	85-	160 26 09
<b>CLUTCH PLATES</b>			
	Front (High/Rev) friction		
	127 x 2.0 x 38T x 104 inside tooth	(3)	160 11 06
	Front (High/Rev) steel 127mm x 3.8 x 24T	(3)	160 12 01
	Forward friction (rear clutch):-		
	127mm x 2.0 x 38T x 104mm inside tooth dia	(3)	160 11 06
	Forward steel 127mm x 1.8 x 24T	(2)	160 12 08
	Low & reverse friction 152mm x 2.0 x 51T	(6)	160 11 04
	Low & reverse steel 155mm x 1.0 x 20T	(5)	160 12 10

Illus	Description		Part No.
<b>BRAKE BANDS</b>			
	Kickdown band - 40mm wide	79-83	160 14 01
	Kickdown band - 44mm wide	84-	160 14 02
<b>FILTER</b>			
	Dacron screen	79-81	160 27 01
	Dacron screen	82-83	160 27 02
	Dacron screen	83-	160 27 07
<b>THRUST WASHERS</b>			
	Stator thrust 1.8 mm		160 22 10
	Stator thrust 2.18 mm		160 22 11
	Stator thrust 2.60 mm		160 22 12
<b>TORQUE CONVERTERS</b>			
	With 12mm dia input journal & ring gear MD707840	79-81	160 30 01
	With 17mm dia input journal & ring gear MD707842	81-	160 30 02
	Galant L/U		
	MD714780		160 30 03
	MD707841		160 30 04
	MD721043		160 30 05
	MD721890		160 30 06
	MD711242		160 30 07
	MD715537		160 30 08
<b>TOOLS</b>			
	Manual		160 33 20